



## Reinforced Earth Company Ltd

6 Hollinswood Court  
Stafford Park 1  
Telford  
Shropshire TF3 3DE  
Tel: 01952 201901 Fax: 01952 201753

**Roads and Bridges  
Agrément Certificate  
No 99/R106**  
Second issue\*

Designated by Government  
to issue  
European Technical  
Approvals

## HIGH ADHERENCE STRIP AND PANEL LUG SYSTEM FOR REINFORCED SOIL RETAINING WALL AND BRIDGE ABUTMENTS

### Product



• THIS CERTIFICATE REPLACES ROADS AND BRIDGES CERTIFICATE No 87/R030 AND RELATES TO THE HIGH ADHERENCE STRIP AND PANEL LUG SYSTEM FOR REINFORCED SOIL RETAINING WALL AND BRIDGE ABUTMENTS.

• The system is based on the use of galvanized, hot-rolled steel strips with transverse ridges formed during the rolling process and galvanized, hot-rolled strip panel lugs to be embedded in precast reinforced concrete facing panels.

• The design and construction must be in accordance with the requirements of the Highways Agency (HA), acting on behalf of the Department for Transport, the Scottish Executive Development Department, the Welsh Assembly Government, and the Department for Regional Development, Northern Ireland, and the conditions set out in the Design Data and Installation parts of this Certificate.

• Marketing, design and supervision of the construction of reinforced soil structures incorporating the system are carried out by the Certificate holder. Formal training is provided where construction is not carried out by the Certificate holder.

## Highways Agency Requirements

### 1 Requirements

1.1 All proposals for adopting the system shall comply with current HA design and certification procedures and relevant Design Data shall be submitted in accordance with the requirements of section 4 of this Certificate.

1.2 The design, materials specification and construction methods adopted shall be in accordance with HA Technical Standard BD 70/03 (use of BS 8006 : 1995), Design Manual for Roads and Bridges (DMRB 2.1.5) and Manual of Contract Documents for Highway Works (MCHW), Volume 1 (MCHW1), May 2001 Edition.

# Regulations

## 2 Construction (Design and Management) Regulations 1994 (as amended) Construction (Design and Management) Regulations (Northern Ireland) 1995 (as amended)

Information in this Certificate may assist the client, planning supervisor, designer and contractors to address their obligations under these Regulations.

See section: 4 Delivery, storage and site handling (4.1).

# Technical Specification

## 3 Description

3.1 The High Adherence Strip and Panel Lug System for Reinforced Soil Retaining Wall and Bridge Abutments system comprises:

- High Adherence Strips
- Panel Lugs
- bolts and nuts for attaching the High Adherence Strips to the Panel Lugs
- frictional fill
- precast concrete facing panels.

3.2 High Adherence Strips (see Figure 1) are manufactured from galvanized, hot-rolled steel strip with transverse ridges. The steel strip is quality S355JR with minimum tensile, bearing and shear strength of  $510 \text{ Nmm}^{-2}$  having a silicon content of not less than 0.20% and not more than 0.35% complying with the requirements of BS EN 10025 : 1993.

Figure 1 High Adherence Reinforcing Strip

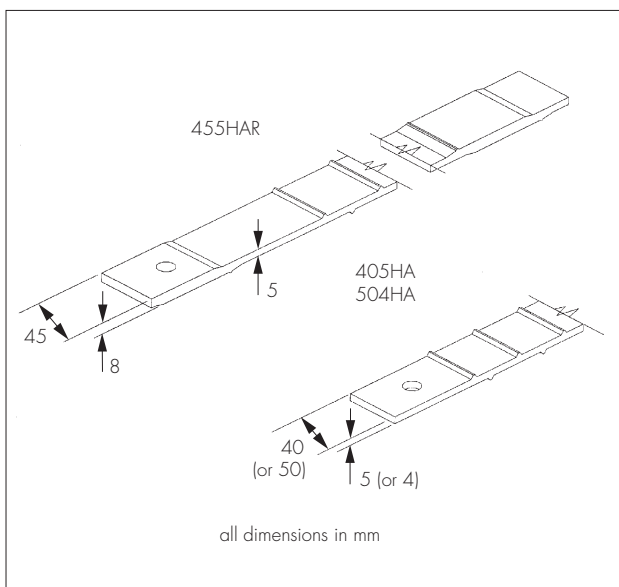

3.3 The Panel Lugs (see Figure 2) are manufactured from galvanized, hot-rolled steel strip. The steel strip is quality S355JR with minimum tensile, bearing and shear strength of  $510 \text{ Nmm}^{-2}$ , having a silicon content of not less than 0.20% and not more than 0.35%, complying with the requirements of BS EN 10025 : 1993.

Figure 2 Panel Lug

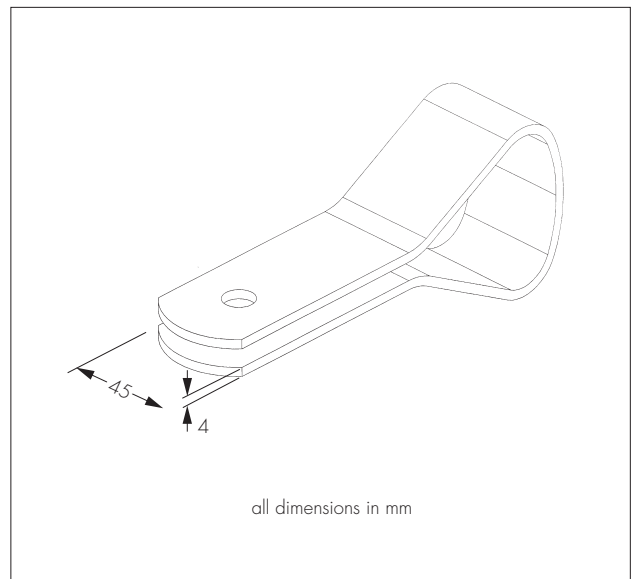

3.4 After fabrication, the High Adherence Strips and Panel Lugs are hot-dip galvanized to BS EN ISO 1461 : 1999, except that the average zinc coating weight for any individual test area is not less than  $1000 \text{ gm}^{-2}$ .

3.5 The 12 mm diameter bolts are steel alloy grade 10.9 to BS 3692 : 2001 or BS EN ISO 4014 : 2001 grade A and BS EN ISO 898-1 : 1999, hot-dip galvanized to BS EN ISO 1461 : 1999.

3.6 The 12 mm diameter nuts are steel alloy grade 8 to BS 3692 : 2001 or BS EN ISO 4032 : 2001, style 1, grade A and BS EN 20898-2 : 1994, hot-dip galvanized to BS EN ISO 1461 : 1999.

3.7 Nominal dimensions and the design strength ( $T_D$ ) of the High Adherence Strips and Panel Lugs are given in Table 1.

Table 1 Properties of High Adherence Strip and Panel Lugs

Type	Nominal width (mm)	Nominal thickness (mm)	Design strength, $T_D$ (1), (2) (kN)	
			Main body	Connection
405HA	40	5	38.8	24.0
504HA	50	4	37.1	25.9
455HAR	45	5	43.9	42.2 <sup>(3)</sup>
Panel Lug	45	4	—	42.2

(1) Assumes a design life of 120 years.

(2) Includes for partial factor  $f_n = 1.1$ , to allow for ramifications of failure — see BS 8006 : 1995, Table 3.

(3) Connection capacity limited by Panel Lug.

3.8 Manufacturers of High Adherence Strips and Panel Lugs shall be BS EN ISO 9002 : 1994 (or equivalent) registered.

3.9 Quality control checks on High Adherence Strips and Panel Lugs during manufacture include chemical analysis, tensile tests and zinc thickness tests.

## 4 Delivery, storage and site handling

4.1 Components should be handled and stored generally in accordance with HA requirements.

4.2 The High Adherence Strips are supplied in bundles. Each bundle carries a label bearing the BBA identification mark and the number of this Certificate.

4.3 Panel Lugs in bundles or crates, each carrying a label bearing the BBA identification mark and the number of this Certificate, are supplied for casting into the precast reinforced concrete panels before delivery to site.

## Design Data

### 5 General

5.1 High Adherence Strip and Panel Lugs are satisfactory for use in providing reinforcement for reinforced soil structures with stability achieved through interaction of the soil particles with the High Adherence Strips. A typical sectional elevation and plan are shown in Figures 3 and 4 respectively.

5.2 Design details, including the required length, type and spacing of High Adherence Strips, are satisfactory when determined in accordance with Technical Standard BD 70/03.

5.3 The arrangement of High Adherence Strip and parapet support structure (as shown on the Certificate holder's drawings Nos S93, S94, S95, and S99) is satisfactory for the requirements of the

design load case associated with vehicle impact on P1 and P2 parapets for highways structures, where the highway design traffic surcharge is HA or up to 45 units of HB. The strip requirement for other load cases, eg HA and/or HB traffic surcharge, is to be determined separately and the maximum strip requirement provided. The anchor beam dimensions shown on the Certificate holder's drawings are satisfactory for the global stability of the anchor beam to prevent overturning and forward sliding, as demonstrated by the results of a full-scale impact test.

5.4 High Adherence Strips are easily installed and are able to withstand the forces imposed by compaction plant provided the composition of the fill and the compaction methods are in accordance with HA requirements, and this Certificate.

5.5 The connection between the High Adherence Strips and the Panel Lugs is easily made.

5.6 To prevent damage, High Adherence Strips must not come into direct contact with compaction plant. Strips must be covered and protected with fill prior to any trafficking.

5.7 Fill should be placed to a minimum depth of 150 mm before each pass of the compaction plant and, to avoid movement of the facing panels, heavy compaction plant should not be employed within 2 m of the face.

5.8 Prior to the commencement of the work, the designer shall satisfy the HA technical approval requirements.

Figure 3 Typical diagrammatic sectional view

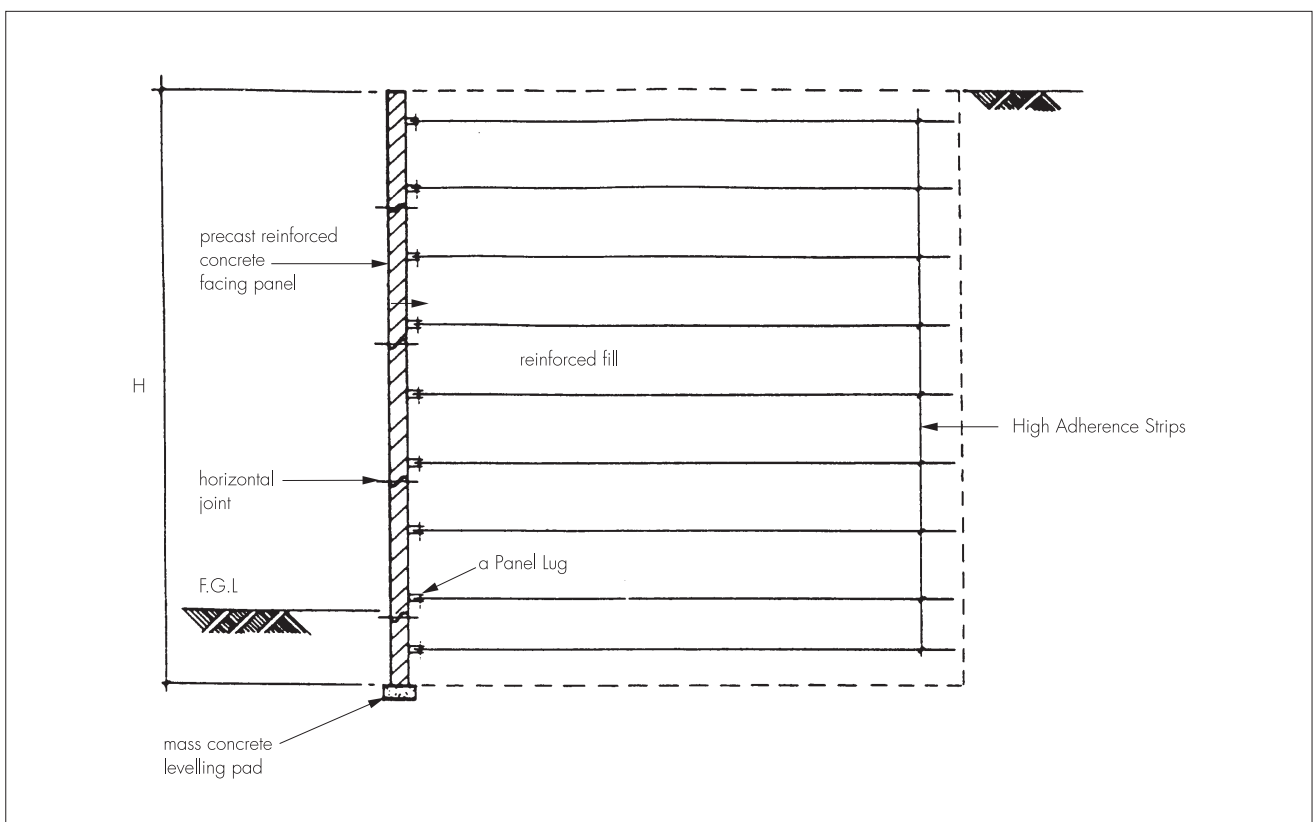
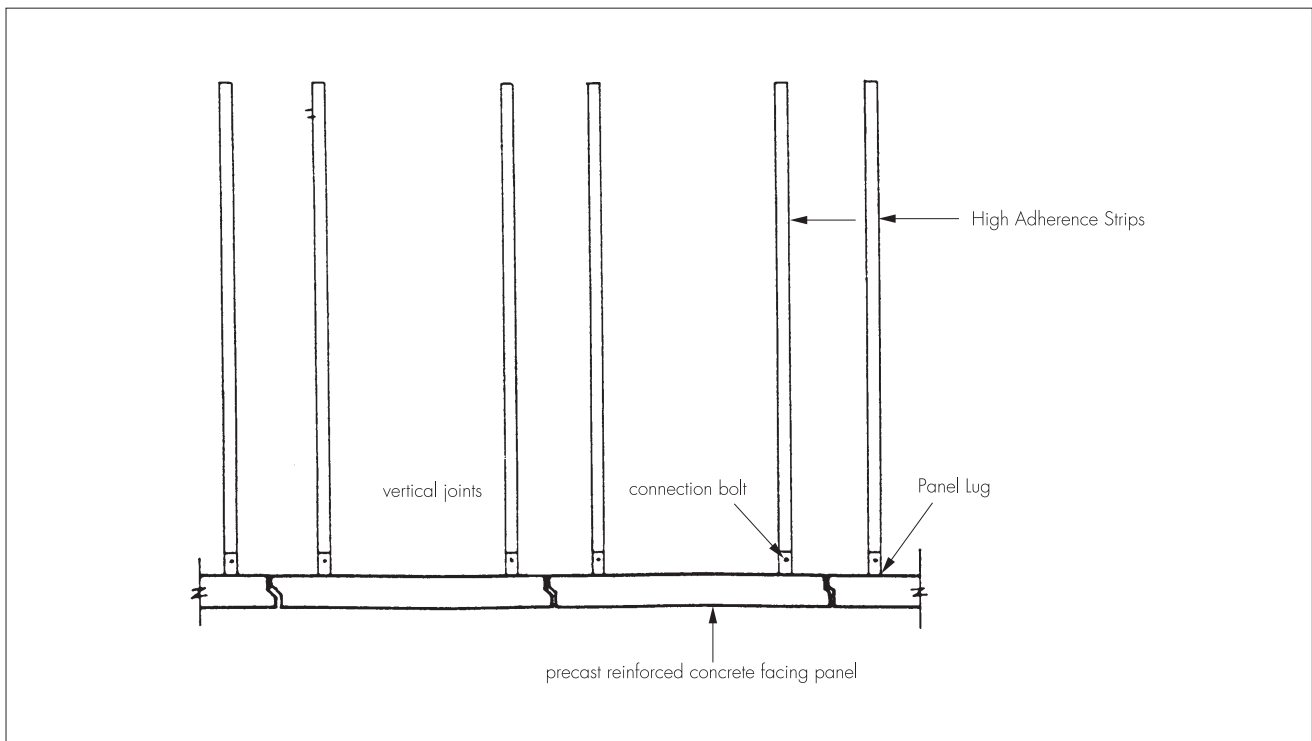

Figure 4 Typical diagrammatic plan view



5.9 Where appropriate to specific projects, the designer should provide the main contractor with details of:

- working drawings
- calculations
- specification for fill material
- acceptable moisture content of fill material at time of placement
- sequence of placing fill material
- estimated movement of facing units during filling and compaction operations
- tolerance on the position of finished line of the wall.

5.10 Where appropriate, the reinforced soil structure should be protected against horizontal impact loads caused by possible vehicle collision with the lower facing units of the wall.

5.11 The precast concrete facing units should be designed to conform to the requirements of HA Technical Standards BD 24/92. Use of BS 5400-4 : 1990 (DMRB 1.3.3) and BD 57/01 (DMRB 1.3.7).

## 6 Design considerations

Reinforced soil structures incorporating the products shall be designed in accordance with BD 70/03, and other HA requirements.

## 7 Mechanical properties

### Design strength ( $T_D$ )

7.1 The appropriate design strength,  $T_D$ , for a particular combination of High Adherence Strip and Panel Lug, may be taken from Table 1, this allows for:

- a design life of 120 years
- a partial material factor,  $f_m = 1.5$
- a partial factor,  $f_n = 1.1$ , dealing with ramifications of failure.

### High Adherence Strip/frictional soil interaction

7.2 The fill material used in the structures shall be 6I or 6J frictional fill as described in MCHW1 with electrochemical properties in accordance with Table 4 of BS 8006 : 1995, or frictional fill material as described in clause 7.3 of this Certificate.

7.3 Fill material used in structures that complies with the following grading limits (see Table 2), has a uniformity coefficient not less than two, and the characteristic parameters defined in clause 7.4 of this Certificate can be used in design without further tests except where the fill is chalk, in which case shear box (300 mm) tests must be carried out. Where fill in the reinforced earth structure is within a vertical distance of 1 m of a trafficked road surface, it must have a uniformity coefficient not less than 5.

Table 2 Fill material grading limits

BS sieve	Percentage passing
125 mm <sup>(1)</sup>	100
75 mm	not less 75
10 mm	not less 10
80 µm	0 to 15

(1) Particles larger than 125 mm and up to 250 mm may be used at the discretion of the engineer.

7.4 For frictional fill complying with the grading requirements of clauses 7.2 or 7.3 of this Certificate, shear strength characteristics<sup>(1)</sup> will be equal to or better than:

- $\phi' = 36^\circ$ , where  $\phi'$  is the effective angle of shearing resistance of the fill
- $\mu^*_{\phi_0} = 1.2 + \log(\text{Uniformity Coefficient})$  and
- $\mu^*_{\phi_{\delta+}} = \tan \phi'$ , where  $\mu^*_{\phi_0}$  and  $\mu^*_{\phi_{\delta+}}$  are defined in Figure 5, and represent enhanced pull-out resistance as described in clause 2.12 of BS 8006 : 1995.

(1) These values are conservative and may be used in routine design of structures in accordance with BD 70/03 unless more definitive data on uniformity coefficient (CU) and  $\phi'$  are available.

Figure 5 Distribution of  $\mu^*$  values used for design

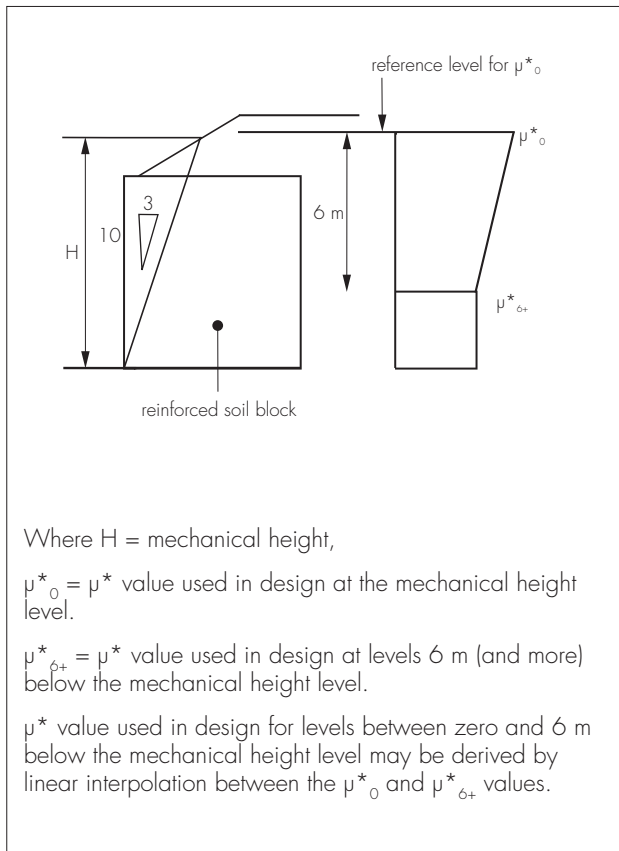

7.5 Definitive data for uniformity coefficient (CU) of the frictional fill can be obtained from particle size distribution tests (where  $CU = D_{60}/D_{10}$ ). Definitive data for  $\phi'$  for the frictional fill can be obtained from shear box (300 mm) tests.

7.6 When the fill has more than 15% passing the 80 micron sieve, special procedures are required for determining the suitability of the frictional fill. These are shown on drawing No S429 available from the BBA or the Certificate holder.

7.7 Frictional fill material containing particles greater than 250 mm is not covered by this Certificate but may be acceptable at the discretion of the engineer. The following provisions should be considered:

- the size of the largest particles is not greater than 70% of the vertical spacing of the High Adherence Strips

- the material is well graded
- frictional fill containing these large particles is not placed within a distance of 2 m of the facing
- compaction of the frictional fill can be carried out to achieve the required density.

### Parapet support structure

7.8 The parapet support units must be constructed to the design of the Certificate holder as approved by the BBA and shown in drawings Nos S94, S95, S98 and S99 available from the BBA or the Certificate holder. The general arrangement is shown in Figure 6.

7.9 The number and layout of the High Adherence Strips below the parapet support structure must be to the requirements of the Certificate holder and approved by the BBA as shown on drawing No S93 available from the BBA or the Certificate holder (see section 5.3).

Figure 6 Parapet support structure general arrangement

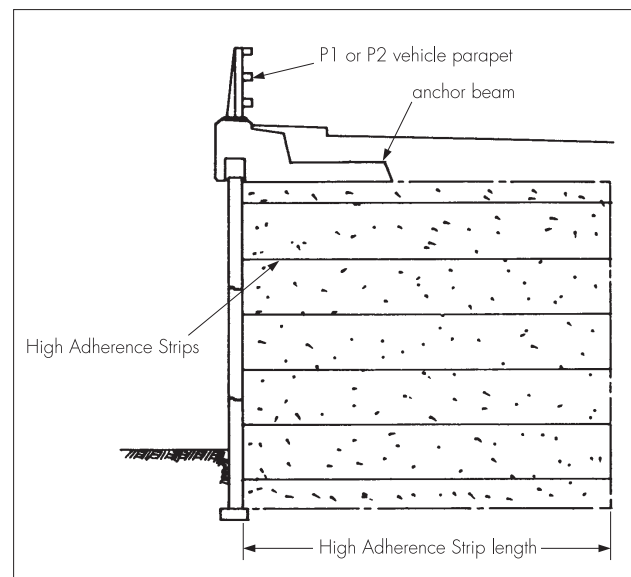

## 8 Durability

In the opinion of the BBA, when used and installed in accordance with this Certificate, the system can achieve a design life of 120 years as required by HA for permanent structures.

## Installation

### 9 Procedure

9.1 The formation level is prepared, the concrete levelling pad constructed and the first course of facing panels erected and temporarily propped.

9.2 Fill material is placed and compacted behind the facing up to the level of the first layer of High Adherence Strips.

9.3 The High Adherence Strips are then laid and attached to the Panel Lug embedded in the precast concrete facing panels, using galvanized steel connection bolts.

9.4 A further course of facing panels is fixed and successive layers of fill are placed and compacted on top of the High Adherence Strips until the level of the next layer of High Adherence Strips is reached. The sequence is repeated up to the required height of the structure.

9.5 The parapet support units are constructed using normal reinforced concrete construction techniques.

## Technical Investigations

The following is a summary of the technical investigations carried out on the High Adherence Strip and Panel Lug System for Reinforced Soil Retaining Wall and Bridge Abutments as part of this and previous BBA assessments.

### 10 General

The system has been assessed for compliance with HA requirements.

### 11 Tests

As part of the assessment resulting in the issue of previous Certificates Nos 81/19 and 87/30, tests were carried out to establish:

- thickness of galvanizing on High Adherence Strips and Panel Lugs
- coefficient of friction between High Adherence Strips and frictional fill
- performance of parapet support structure under full-scale impact test.

### 12 Investigations

As part of this and previous assessments, the following investigations were carried out.

- (1) Existing data on the High Adherence Strip were examined in relation to:
  - coefficient of friction between the strips and the fill
  - quality and composition of steel
  - tensile properties of steel
  - quality of galvanizing
  - design calculations.
- (2) Existing data on the Panel Lug were examined in relation to:
  - quality and composition of steel
  - tensile properties of steel
  - quality of galvanizing
  - design of High Adherence Strip/Panel Lug connection.
- (3) Existing data relating to the quality of the bolts were examined.
- (4) The manufacturing processes for the High Adherence Strip and Panel Lugs were examined, including the methods of quality control.

(5) A visit was made to site to assess the practicability of installation.

(6) Test data and design calculations relating to the parapet support units were examined.

## Additional Information

All suppliers of the High Adherence Strip and Panel Lug System components to the Certificate holder's specification are required to have had their management systems assessed and registered as meeting the requirements of BS EN ISO 9002 : 1994.

## Bibliography

BS 3692 : 2001 *Iso metric precision hexagon bolts, screws and nuts — Specification*

BS 5400-4 : 1990 *Steel, concrete and composite bridges — Code of practice for design of concrete bridges*

BS 8006 : 1995 *Code of practice for strengthened/reinforced soils and other fills*

BS EN 10025 : 1993 *Hot rolled products of non-alloy structural steels — Technical delivery conditions*

BS EN 20898-2 : 1994 *Mechanical properties of fasteners — Nuts with specified proof load values — Coarse thread*

BS EN ISO 898-1 : 1999 *Mechanical properties of fasteners made of carbon steel and alloy steel — Bolts, screws and studs*

BS EN ISO 1461 : 1999 *Hot dip galvanized coatings on fabricated iron and steel articles — Specifications and test methods*

BS EN ISO 4014 : 2001 *Hexagon head bolts — Product grades A and B*

BS EN ISO 4032 : 2001 *Hexagon nuts, style 1 — Product grades A and B*

BS EN ISO 9002 : 1994 *Quality systems — Model for quality assurance in production, installation and servicing*

BD 24/92 *The design of concrete highway bridges and structures use of BS 5400-4:1990*

BD 57/01 *Design for Durability*

BD 70/03 *Strengthened/Reinforced Soils and other Fills for Retaining Walls and Bridge Abutments*

Manual of Contract Documents for Highway Works, Volume 1 : *Specification for Highway Works* : May 2001 edition

## Conditions of Certification

### 13 Conditions

13.1 This Certificate:

- (a) relates only to the product that is described, installed, used and maintained as set out in this Certificate;
- (b) is granted only to the company, firm or person identified on the front cover — no other company, firm or person may hold or claim any entitlement to this Certificate;
- (c) has to be read, considered and used as a whole document — it may be misleading and will be incomplete to be selective;
- (d) is copyright of the BBA.

13.2 References in this Certificate to any Act of Parliament, Regulation made thereunder, Directive or Regulation of the European Union, Statutory Instrument, Code of Practice, British Standard, manufacturers' instructions or similar publication, shall be construed as references to such publication in the form in which it was current at the date of this Certificate.

13.3 This Certificate will remain valid for an unlimited period provided that the product and the manufacture and/or fabricating process(es) thereof:

- (a) are maintained at or above the levels which have been assessed and found to be satisfactory by the BBA;
- (b) continue to be checked by the BBA or its agents;

(c) are reviewed by the BBA as and when it considers appropriate; and

(d) remain in accordance with the requirements of the Highways Agency.

13.4 In granting this Certificate, the BBA makes no representation as to:

- (a) the presence or absence of any patent or similar rights subsisting in the product or any other product;
- (b) the right of the Certificate holder to market, supply, install or maintain the product; and
- (c) the nature of individual installations of the product, including methods and workmanship.

13.5 Any recommendations relating to the use or installation of this product which are contained or referred to in this Certificate are the minimum standards required to be met when the product is used. They do not purport in any way to restate the requirements of the Health & Safety at Work etc Act 1974, or of any other statutory, common law or other duty which may exist at the date of this Certificate or in the future; nor is conformity with such recommendations to be taken as satisfying the requirements of the 1974 Act or of any present or future statutory, common law or other duty of care. In granting this Certificate, the BBA does not accept responsibility to any person or body for any loss or damage, including personal injury, arising as a direct or indirect result of the installation and use of this product.



In the opinion of the British Board of Agrément, the High Adherence Strip and Panel Lug System for Reinforced Soil Retaining Wall and Bridge Abutments is fit for its intended use provided it is installed, used and maintained as set out in this Certificate. Certificate No 99/R106 is accordingly awarded to Reinforced Earth Company Ltd.

On behalf of the British Board of Agrément

A handwritten signature in black ink, appearing to read 'P. Q. Newson', is written over a light grey background.

Date of Second issue: 13th August 2003

Chief Executive

*\*Original Certificate issued on 15th March 1999. This amended version includes revised references to the Highways Agency requirements, addition of CDM Regulations, updated British Standards and Bibliography and new Conditions of Certification.*

---

**British Board of Agrément**

P O Box No 195, Bucknalls Lane  
Garston, Watford, Herts WD25 9BA  
Fax: 01923 665301

©2003

e-mail: [mail@bba.star.co.uk](mailto:mail@bba.star.co.uk)  
website: [www.bbacerts.co.uk](http://www.bbacerts.co.uk)



For technical or additional information,  
contact the Certificate holder (see  
front page).  
For information about the Agrément  
Certificate, including validity and  
scope, tel: Hotline 01923 665400,  
or check the BBA website.